

ZERO WASTE FOUNDATIONS INSTALLATION INSTRUCTIONS

Please read carefully- if installed correctly there will be ZERO damage to concrete footing or surrounding paving impact after impact for the entire lifespan of a development.

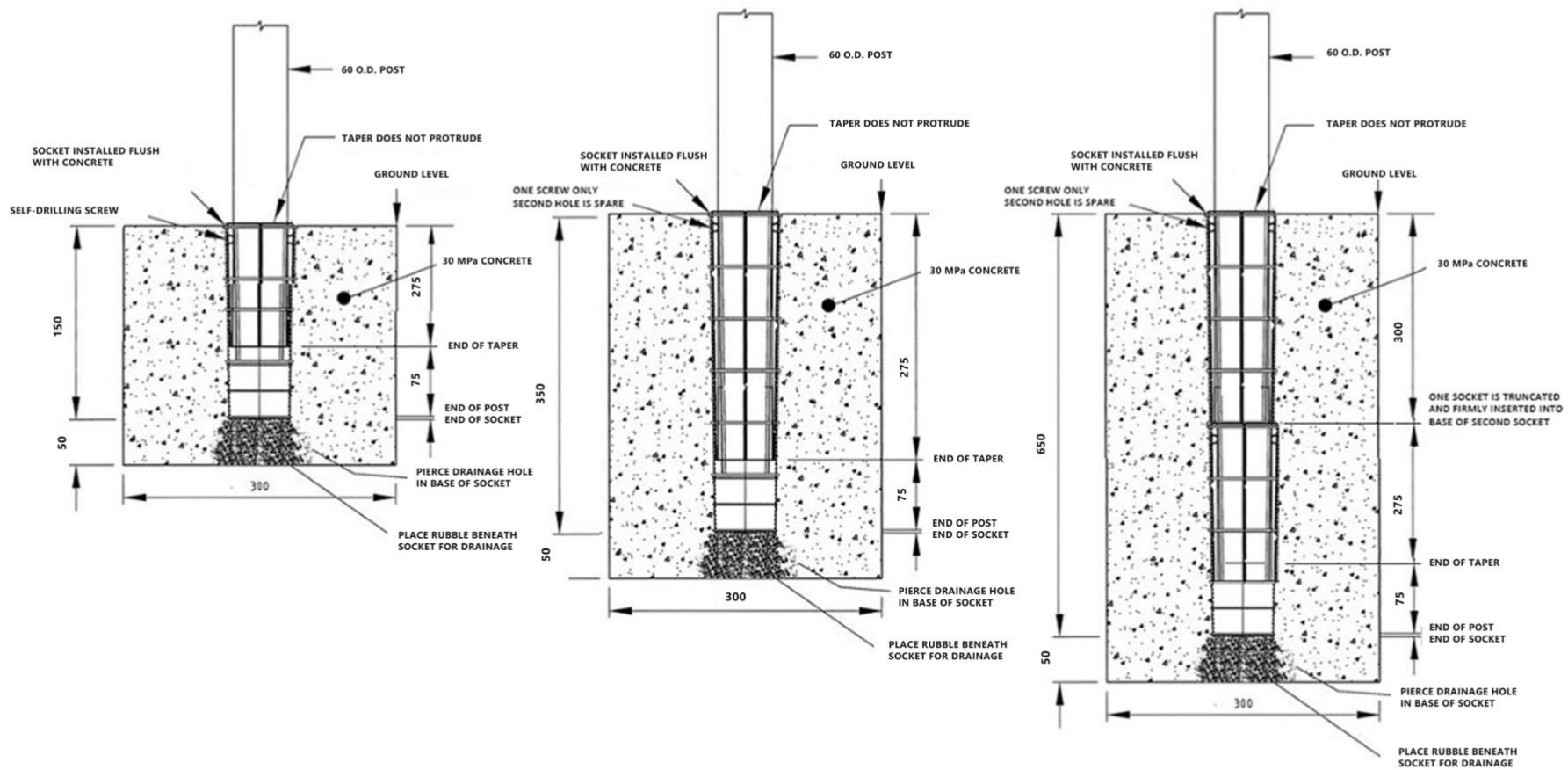



ZEROWASTE
UNBREAKABLE FOUNDATIONS



INSTALLING ZERO WASTE FOUNDATIONS

ZERO WASTE Foundations can be used to install any size or weight item (Refer to User manual and Specifications) from signposts, to barriers, bollards and street furniture.



(A) Ground Socket (B) Self-locking Taper (C) Screws (D) Cap (E) Installation Tool (F) Spirit Level (G) Concrete (H) Paving

IMPORTANT

1. Ground socket must be flush with ground level
2. Rapid set is NOT impact resistant (To be impact resistant concrete must be 30 MPa or greater)
3. Concrete footing must be large enough to ensure it is not dislodged when item is impacted– refer to local guidelines as conditions differ from region to region.
4. Paving is NOT impact resistant- so you must use a min of 150 mm concrete on all sides of ground socket.
5. If you want drainage- pierce hole in base of socket (weak spot provided) and place rubble beneath socket.
6. When you remove item or tool, insert cap to prevent ingress of water, concrete and grit.

SOCKET INSTALLED FROM 150 MM DEPTH

You can extend depth by truncating one socket and placing firmly inside a second ground socket to extend depth by 300 mm increments.

Socket can be reduced to 150 mm depth for installation in solid concrete pavements. Refer to User Manual for details.

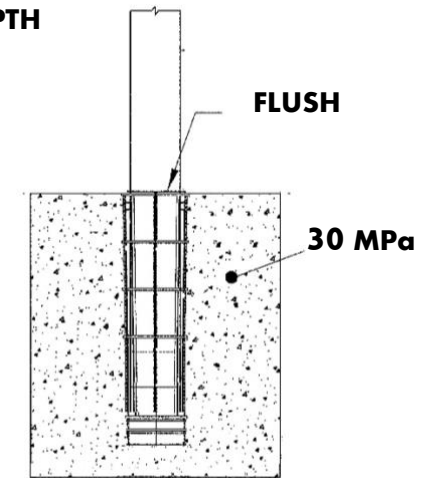

ATTACH TAPER

Attach Taper to post using self-drilling screws provided (only one screw per half taper- second hole is spare). **TAPER MUST BE ATTACHED**, or items will NOT be removable using tools. If using posts 2.9 wall thickness or greater you might want to pre-drill

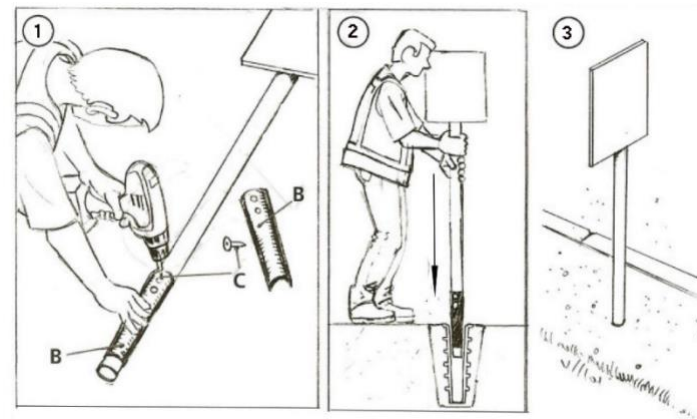

INSTALLING GROUND SOCKET

Insert item gently into ground socket, position socket upright in hole and pour concrete. Check alignment before concrete cures.

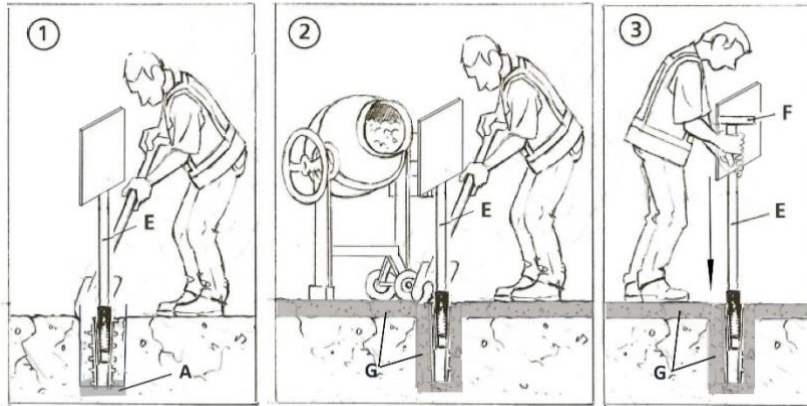

USING INSTALLATION TOOL

When installing large items; in strong winds; when items are not ready to install; or when you do not have time to wait for concrete to cure, you can use installation tool to position socket upright in hole and fill with concrete. Check alignment, twist tool to remove and cap off until concrete cures.

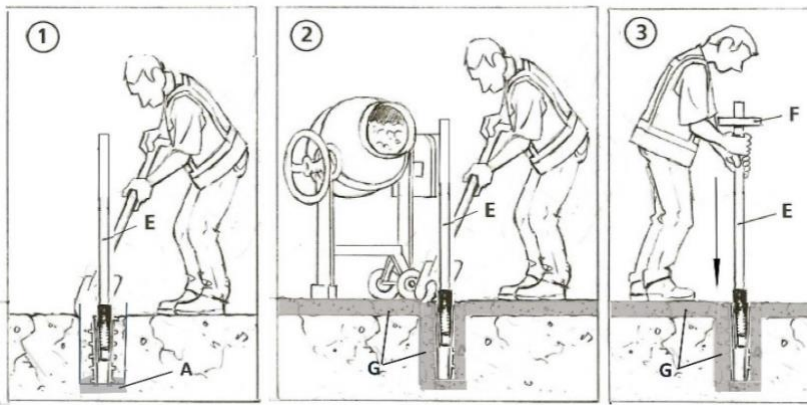

RETRO-FITTING

Core drill hole 80 + mm diameter. Place rubble beneath socket and a little concrete. Use installation tool to position socket upright in hole and fill hole with concrete flush with ground level. Check alignment, twist tool to remove and cap off clean off surface (sign your name) and wait until concrete cures.

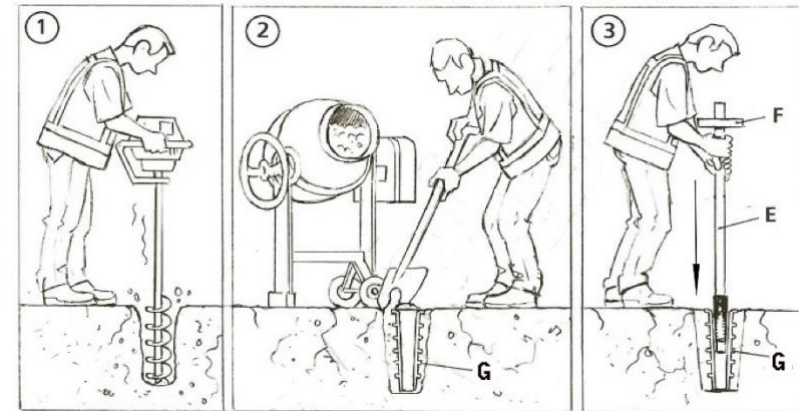

(A) Rubble (B) Taper (C) Self-drilling screws (D) Dave the Installer
(E) Item/ Installation Tool (F) Spirit Level (G) Concrete 30 MPa

CONTACT US FOR MORE DETAILS

Visit web site to view videos and detailed specifications – including what NOT TO DO – It is a good idea to make new installers view this video to avoid problems.

08 9248 5545
hello@zerocivil.com
zerocivil.com

