

ZER 

WASTE FOUNDATIONS

**READ
THIS.**



Ground sockets are installed flush with ground level.

Protecting surrounding concrete and paving from damage when items are impacted. No dangerous trip factors. Items can be removed and ground socket capped.



Items are dropped into ground socket automatically locking in

When impacted by a vehicle the post bends and the socket and taper absorb the impact force protecting the surrounding foundations from damage. Items can be easily removed using tools provided and replaced in less than 5 minutes



Impact-absorbing polymer socket

Advanced polymer construction helps absorb impact energy and protect surrounding foundations.



Reinforced body

Vertical and horizontal ribs provide added strength and stability.

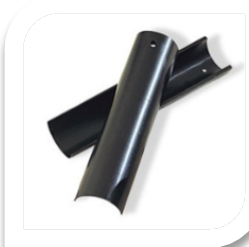

Ribbed base

Allows sockets to be joined to extend depth – no glue required. Tight fit.



Flexible depth options

Standard 350 mm depth, with shorter or deeper options available to suit site conditions.

Drainage-ready base

Weak spot provided to allow drainage.

Reusable self-locking taper

The taper attaches to item using screws provided and finishes flush when installed.

Reusable cap included

For use during installation and when items are removed.

Every component is designed to reduce damage, simplify replacement and extend service life.



Installation tool used to correctly align socket, enables installation of ground socket from standing position

Standard tool comes fitted with Taper to install 350 mm ground sockets.

- To install 150 mm depth socket, re-attach 150 mm Taper to tool in position marked (160 mm from base).
- To install 650 mm depth ground socket, re-attach Taper at position marked (660 mm from base)

This ensures taper does not lock in and the tool is removable by spinning and lifting once concrete has cured.

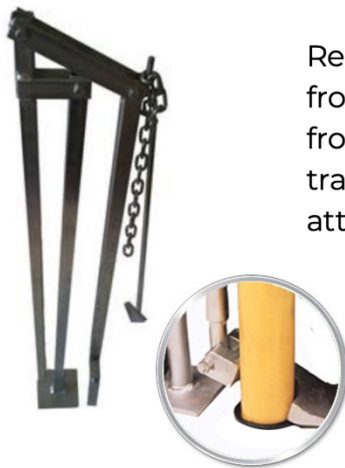

Removal tool used to lever items from ground socket, operated from standing position, facing traffic, (sheared post removal attachment included)

IMPORTANT

1. Ground sockets MUST be installed flush with ground level.

No ground socket protruding from pavement or concrete footing. So that it cannot be damaged when impacted and provides no trip factors.

2. Concrete MUST be 30MPa or greater to be impact resistant.

Ground sockets must be installed flush with ground level with 150 mm of quality 30MPa concrete on all sides to protect surrounding paving and socket from damage when items are badly impacted. Rapid set is NOT impact-resistant /grout is too flexible and will not last 100 years. Colour concrete to suit surrounding paving or foundations.

3. Taper MUST be attached using screws provided

If Taper is not attached to item using screws provided items will NOT be removable from ground socket Taper must be attached at exact level (5mm alters locking capacity by around 150kgf).

4. Taper MUST be installed flush with ground level.

With top of socket (ground level) NOT protruding from ground socket. This ensures taper is re-usable following impact and item is locked in sufficiently. To fully install- firmly tap item until taper is fully installed – this way no dirt and grit will enter, and item will be safely secured

5. Installation tool MUST be used

The installation tool prevents socket from distorting when concrete is impacted- this ensures correct locking capacity of taper. When installing grabrails you can sue grabrail as your installation tool.

EXTENDING DEPTH OF SOCKET

You can increase the depth by 300 mm increments by truncating a ground socket just below the second horizontal rib and inserting it firmly into the top of a complete ground socket

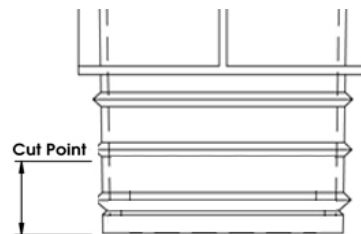

REDUCING DEPTH OF SOCKET

For solid concrete traffic islands or footpaths, you can reduce socket to 150 mm depth.

Truncate the ground socket at exactly 150 mm from top lip, (just below the second horizontal ring from the top) remove base of socket just above bottom rib (as shown right), flip base over and insert into the open end of the truncated ground socket.

This provides a tight fit but can be sealed with industrial glue or weld as an extra precaution. NB: You will need to reduce Taper to 140 mm accordingly.

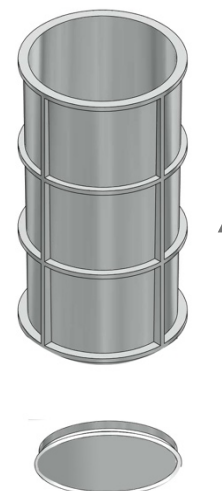
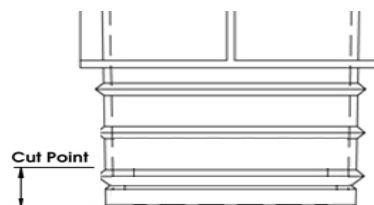

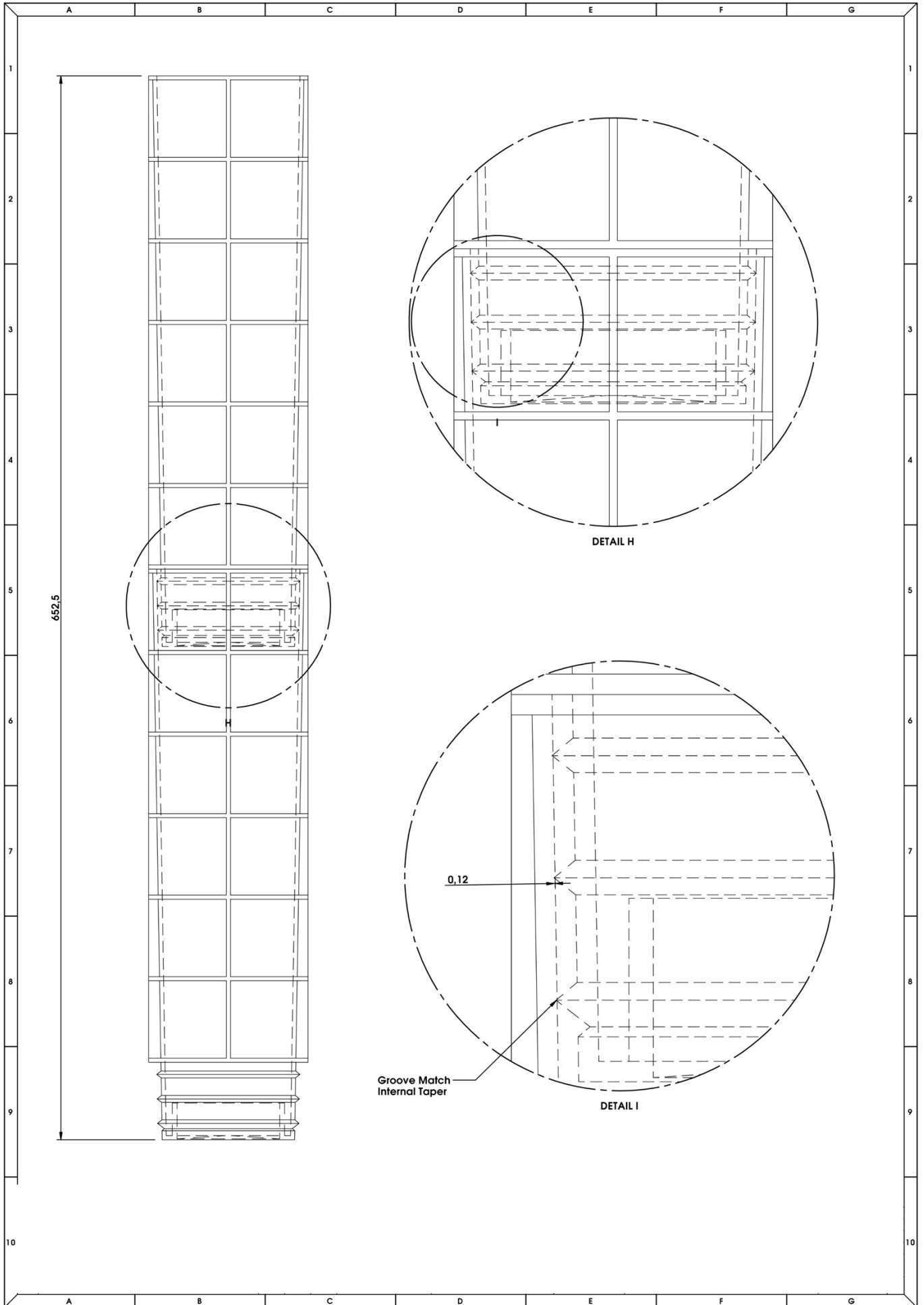

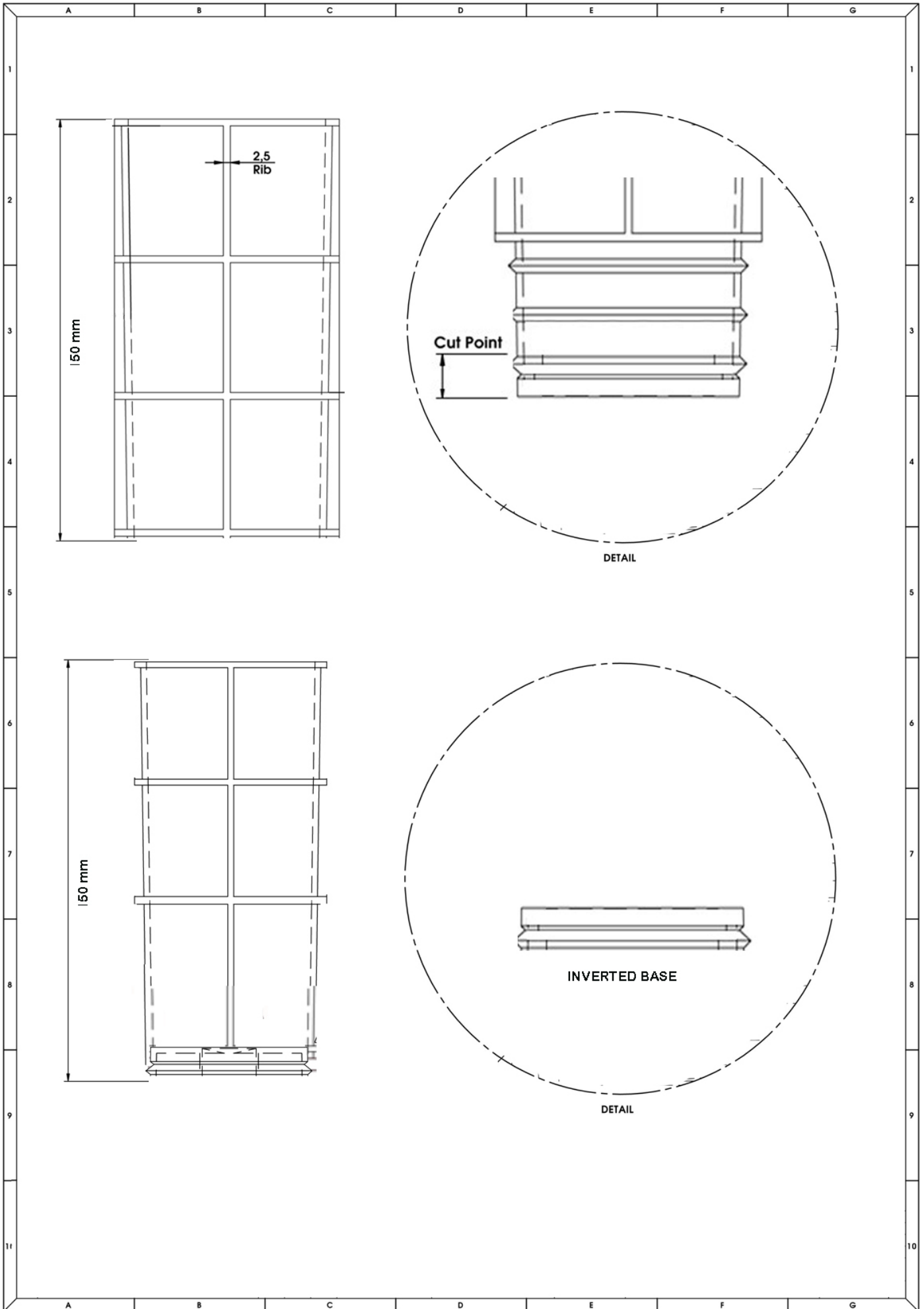

NO SIZE OR WEIGHT LIMITATIONS

There is no limit to the size or weight item you can install using the ZERO WASTE Foundations. Install bins, seating, tables, barriers, signage, shopfront bollards, large bollards (using the Impact Recovery System). It is the size of the concrete footing that determines the weight bearing- not the protective socket.

FOOTING MUST BE LARGE ENOUGH TO NOT BE DISLODGED

For the footing to be reusable you must ensure it is large enough that it is not dislodged when items are impacted. You may need a little more concrete to ensure it will last years and will not need replacing.

The size footing depends on soil conditions, strength of post, size of item, wind conditions, possible impact force and many other factors. Refer to local guidelines for details

We suggest:

- 150 mm depth x 150 mm min diameter in solid concrete
- 350 mm depth x 400 mm in diameter in all other locations
- 650 mm depth x 400 mm in diameter for large or heavy items such as football posts/ columns/ pergolas/ or large diameter bollards that may be subject to extreme impact (Refer to Extra Heavy Duty Impact Recovery System)

DRAINAGE

If you want your sockets to drain of any water, simply pierce hole in base (weak spot provided) using screwdriver or drill, and place rubble beneath socket to allow drainage.

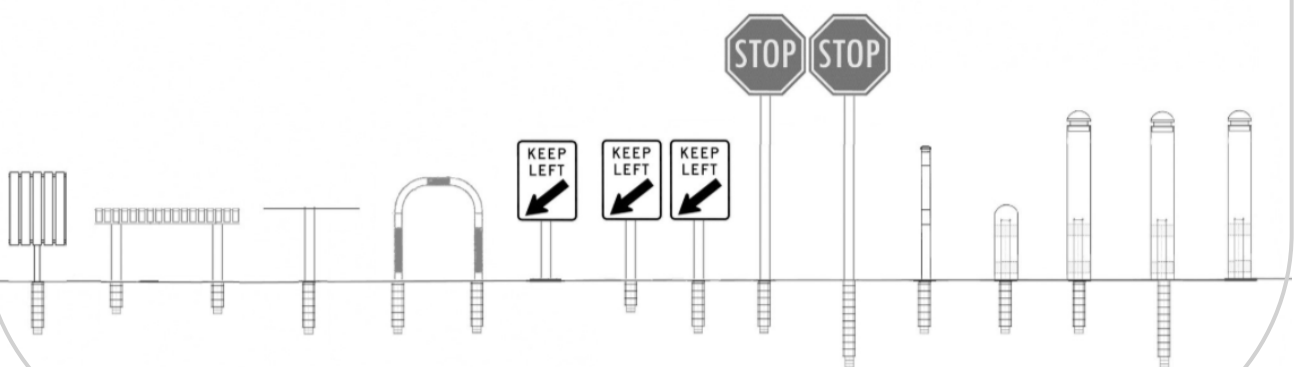

PAVED AREAS / ASPHALT

Installing into existing paving or when installing paving.

Ground Socket is installed flush with surface of paving and must be completely encased in a minimum of 150 mm solid 30 MPA concrete on all sides to protect brick paving from damage when items are impacted.

Remove pavers or core drill, ensuring ground socket finishes level with road or footpath (allowing a minimum of 150 mm of concrete on all sides of socket) – if you are laying paving refer to New works as you can install sockets when pouring concrete foundations.

NB: Make sure you install caps before spraying asphalt or any time before items are installed to avoid grit entering socket.

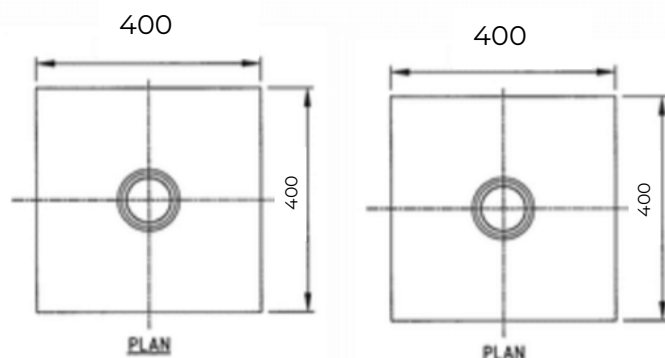
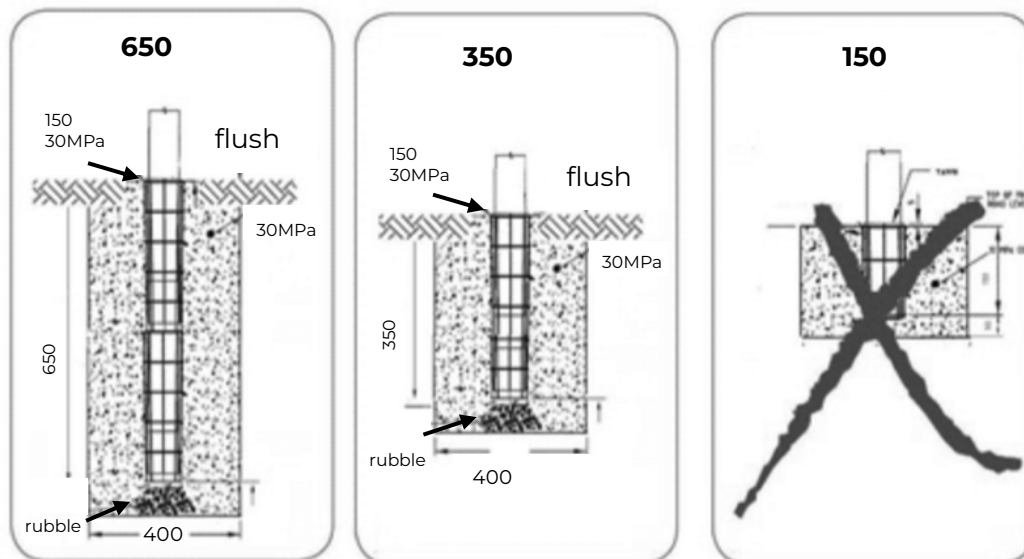

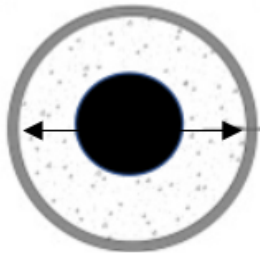

MIN 150 MM CORE

TO PROTECT PAVING FROM DAMAGE

When core drilling, a minimum of 150 mm solid 30 MPA concrete is required to surround socket and protect brick paving from damage when items are impacted.

DO NOT USE RAPID SET OR FLEXI GROUT

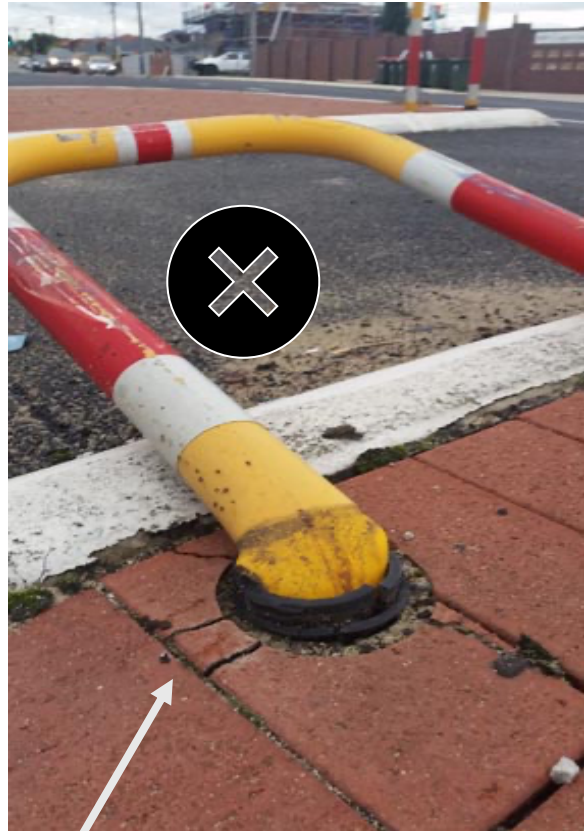

If the socket is not surrounded by at least 150 mm of 30 MPa concrete, adjacent paving may be damaged on impact, as the socket is designed to deform to absorb impact forces and paving alone is not sufficient to withstand those loads.

SOLID EXISTING FOUNDATION

Such as asphalt carpark/ solid concrete footpath or traffic island min 200 mm thick.

Ground Socket is installed flush with surface and must be completely encased in a minimum of 150 mm solid 30 MPA concrete on all sides to protect surrounding foundations from damage when items are impacted.

Core drill hole large enough to fit socket and fill gap with quality concrete to secure ground socket to existing foundation. We recommend 150 mm - 350 mm ground sockets (650 mm is not necessary in solid concrete footpaths or foundations) NB: Sockets can be easily truncated to 150 mm and base reinserted.

Drainage:

If you want drainage: Hole can be pierced in bottom of socket using drill or screwdriver (weak spot provided and rubble can be placed beneath socket if you want drainage).

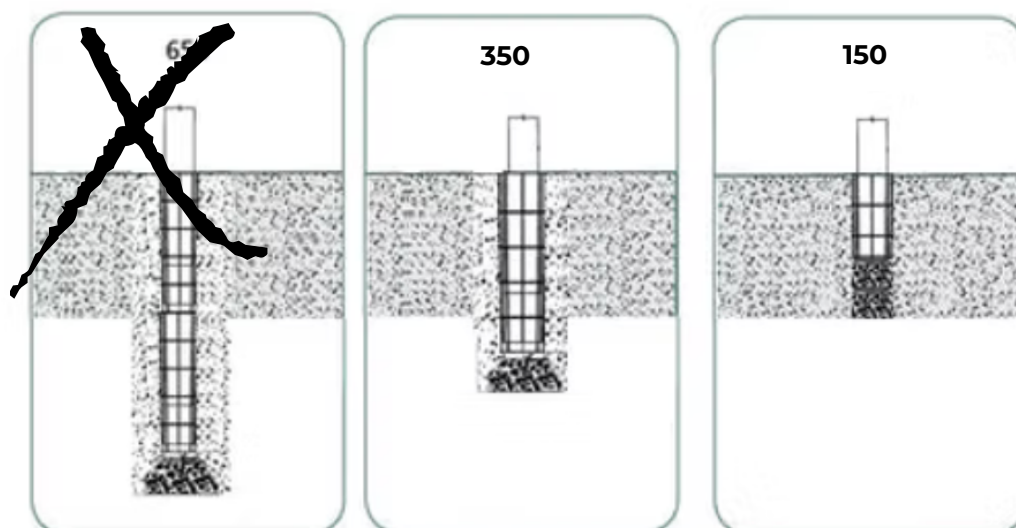

FREE-STANDING ITEMS - SOIL

Socket is installed flush with surface and must be completely encased in concrete. When installing items directly in soil you need a large footing, so it is more imperative than ever that you make the concrete reusable (must be 30MPa+ to be impact resistant).

NB: Socket does not alter the size concrete footing required- it is simply a protective shield to make the concrete footing re-usable.

We recommend you install a 650 x 400 mm diameter foundation (for bollards likely to be impacted by trucks or heavy vehicles) to provide stability and ensure against dislodgement when bollard is impacted. In sandy soil you may need to reinforce the footing using a reo cage.

Remember these footings will last 100 years if installed correctly, so a little more concrete is money well spent.

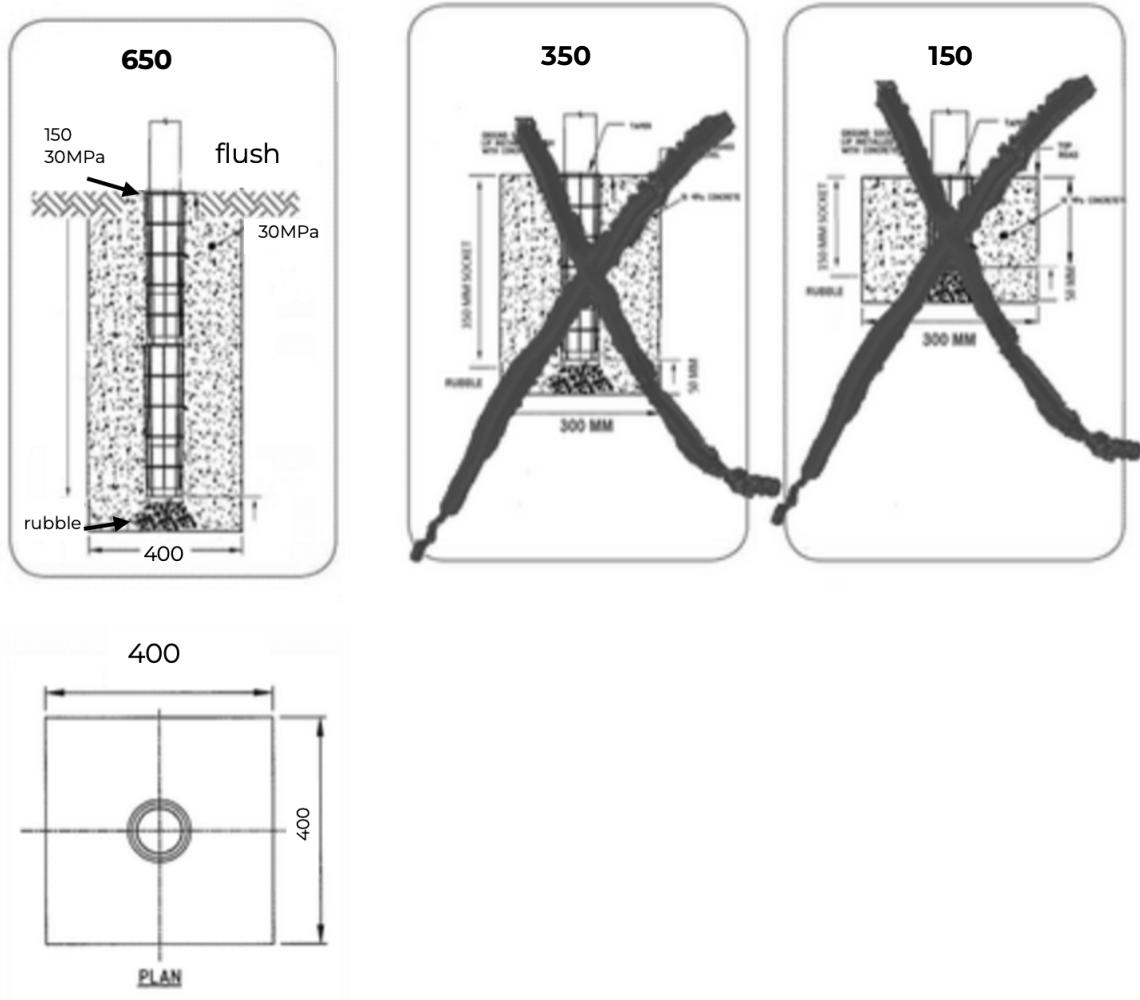

INSTALLING ITEMS WITH MULTIPLE LEGS

If ground is uneven install both sockets flush with ground level. Place item in sockets and mark on each leg where to attach Taper so it finishes flush with top of ground socket.

Remove item and install sockets as usual.

Attach Taper using self-drilling screws and drop item in socket once concrete has cured. Tap item down firmly until taper finishes flush with ground level. Suitable for bike racks, grabrails, barriers.

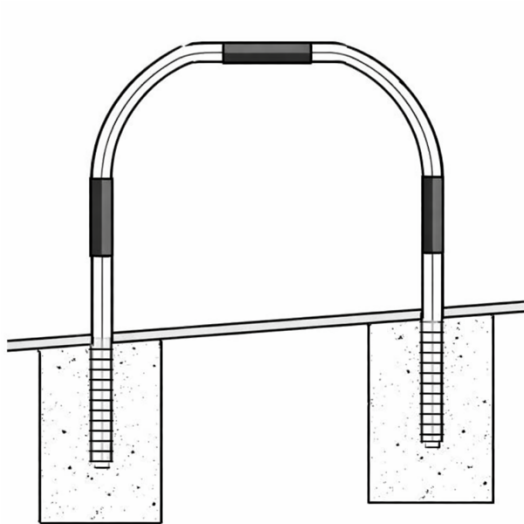

INSTALLING BOLLARDS

165/150 mm steel bollards/ 168 mm stainless steel Bollards or 150 mm Advanced Polymer Bollards (available from Zero Civil) can be installed on the same 60 mm foundations using our **Bollard Impact Recovery System** that:

- Makes bollards impact resistant and
- Makes both bollards and surrounding foundations re-usable impact after impact, saving thousands over the life of a development.

Bollards remain safe, secure and upright and if badly impacted are replaced in less than 5 minutes. This also means bollards can be installed and removed whenever required and easily relocated. No more expensive maintenance and no need to throw away a bollard or the expensive footings again! **(Surface Mount option available)**

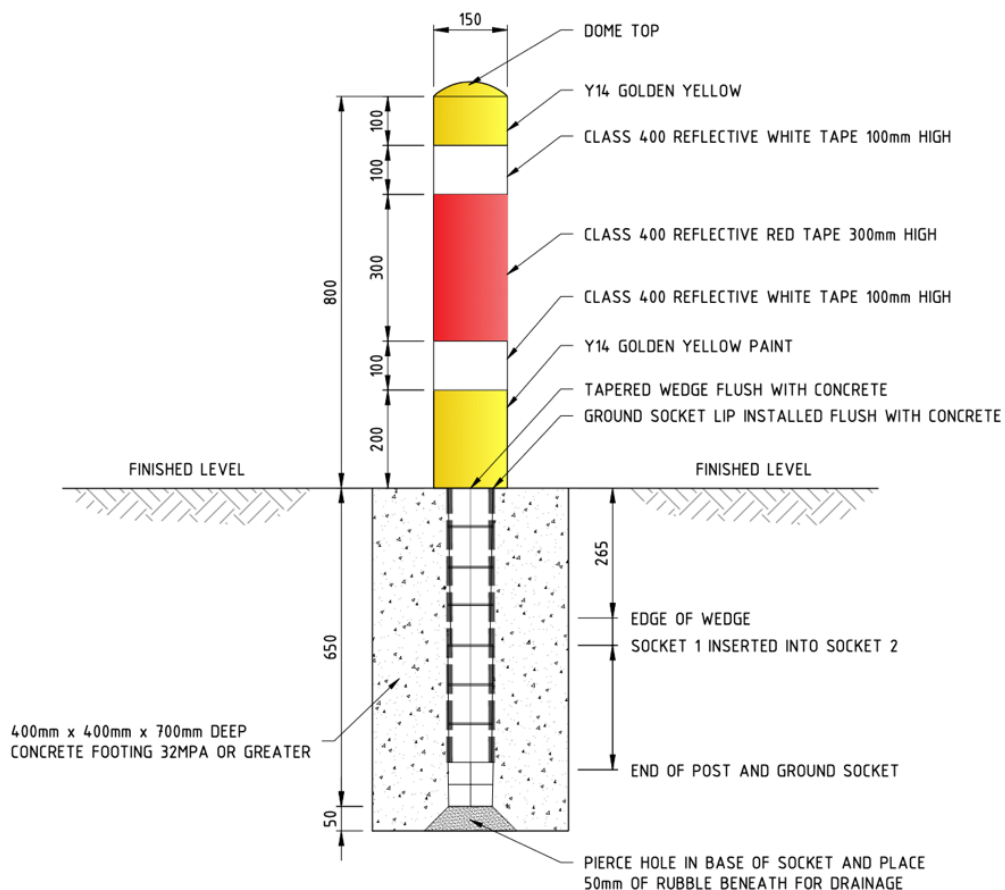

INSTALLING ground sockets

ZERO WASTE FOUNDATIONS OUR NO.1 INNOVATION

FOR MORE DETAILS SCAN HERE



01

To install socket you will need:

- Ground Socket
- Cap
- Installation Tool
- Small amount of rubble
- Concrete (30MPa)
- Spirit Level
- 10 mm Masonry Drill Bit
- PH2 Phillips Screwdriver Bit
- Drill / Driver
- Pigment to colour concrete (optional)



STEP 1.

Installation tool is used to position socket in hole and check alignment using a spirit level



STEP 2.

Position socket upright using rubble and a little concrete and check alignment using spirit level before pouring concrete to secure (allow room for paving if necessary)



STEP 3.

Socket must be flush with ground level (leaving space for paving or asphalt) no trip factors.

Make sure installation tool is still installed (or socket is capped) pour 30Mpa concrete to ground level and clean off surface.

NB: Good idea to colour match is going into paving and make sure you install a minimum of 150 mm concrete on all sides of socket to protect paving from damage)

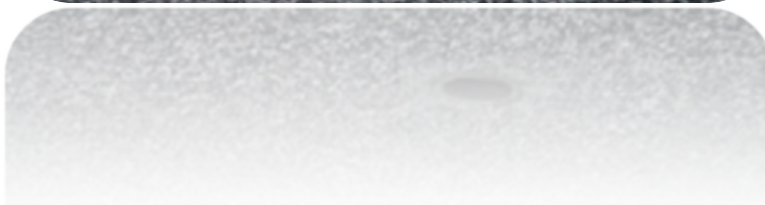

INSTALLING items

ZERO WASTE FOUNDATIONS OUR NO.1 INNOVATION

FOR MORE DETAILS SCAN HERE



01

STEP 1.

Attach Taper using self-drilling screws (if using 2.9 or heavier walled steel we suggest pre-drilling)

This can be done in yard in advance or on location.



STEP 2.

Once concrete has cured, drop item firmly into ground socket.

Tap item firmly until taper finishes flush with ground level – this provides enough locking power to ensure items cannot be removed without tools and that taper will not be damaged when items are badly impacted.



When impacted

When lightly impacted post can be bent.
If badly impacted post will fold but items remain firmly seated in the ground socket.

No damage to footings and items can be removed using ergonomic tools provided.

Flattened posts are removed by slipping base of tool under the item and levering up, to break the seal, then use tools as usual.

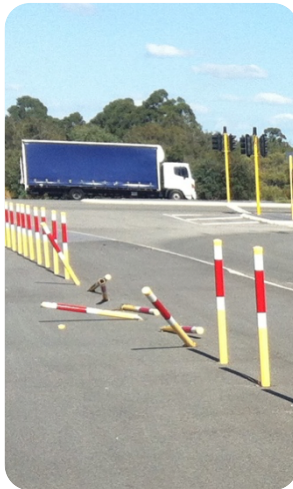

Quickly transition

If used on every damaged item within 2-3 years, the majority of your more vulnerable items will have been replaced with ZERO WASTE Foundations.





The reason this is so important is that 20 % of items in most cities are responsible for around 80% of your workload.

This means that although it will take around 50 years to make all locations sustainable a maximum of 20% of all future work will require digging and heavy labour, and each year your job will get easier.







DID YOU KNOW?

There are approximately 100,000 strikes per year to dangerous underground services

DID YOU KNOW?

Concrete is considered the world's most dangerous material

INSTALLING Bollards

IMPACT RECOVERY SYSTEM OUR NO.2 INNOVATION

FOR MORE DETAILS SCAN HERE



02

INSTALLING Surface Mount Bollards

02

To install Base Plate, you will need:

- Base Plate
- M12 x 150mm Galvanised Countersunk (10mm In/Hex) Screw bolt Anchors
- Masonry drill bit 10 mm
- Hammer drill
- Hex drill bit



STEP 1. Surface Mount

1. Place base plate on footing and mark where to drill holes to accept concrete anchors.
2. Drill holes
3. Clear holes of concrete dust and insert concrete anchors provided (flush mounted recessed anchors)



STEP 2.

Secure resistance core to base plate using securing stud provided.

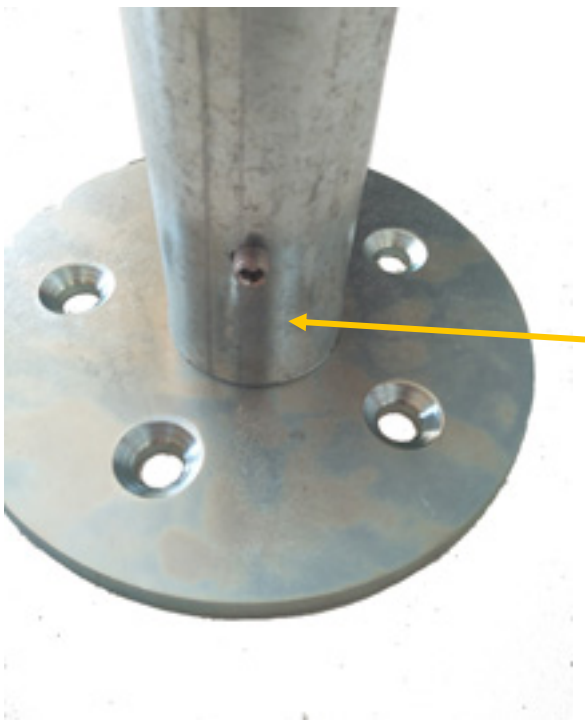

STEP 3.

Tighten clamps to secure rings to resistance core (top one facing down, bottom one facing upward)

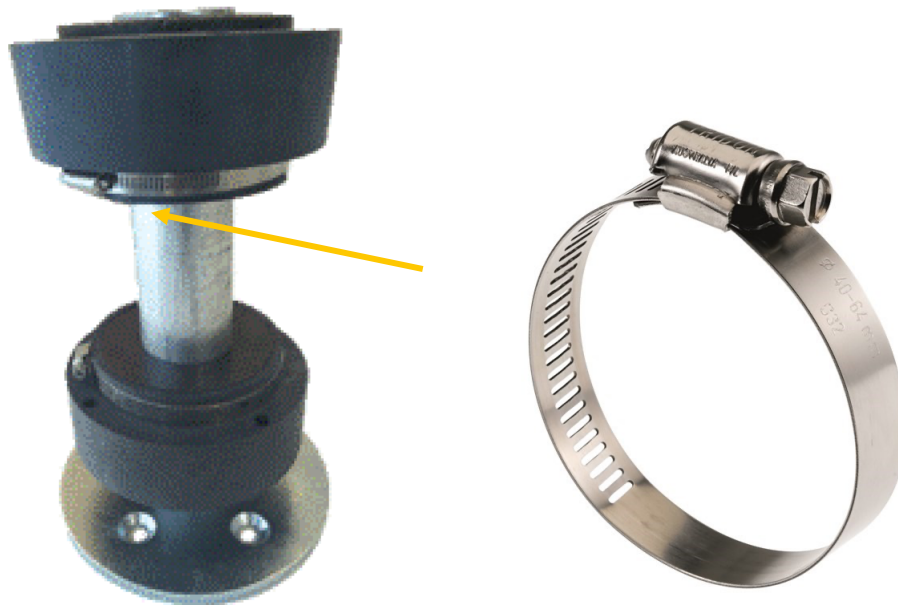

STEP 4.

Slip bollard over rings and secure stud beneath bottom ring.

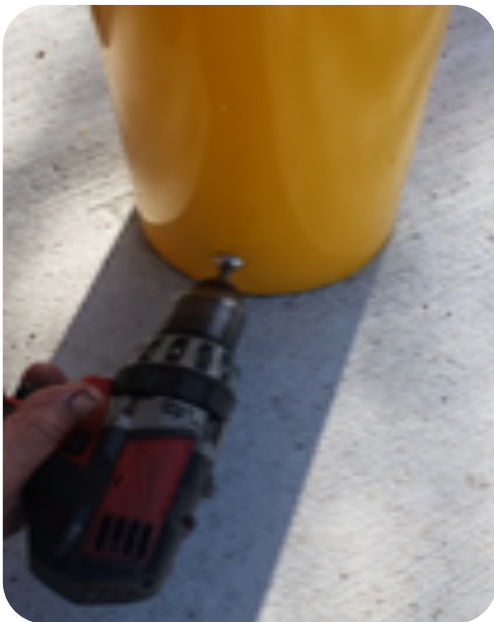

INSTALLING In-ground Bollards

02

To install inground bollards you will need

1. Screwdriver (or drill and screw driver bit)
2. Allen key



STEP 1.

Use screwdriver to tighten clamps to secure rings to resistance core (top one facing down, bottom one facing upward)



STEP 2.

Forcefully drop Resistance core into ground socket. It will automatically lock in.

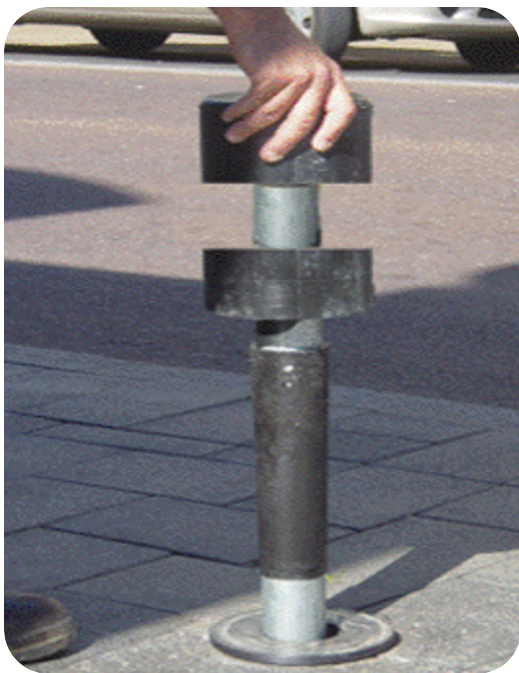

Optional: Protector cuff available to protect paving from scuffing

STEP 3.

Slip bollard over rings and secure stud beneath bottom ring using Allen key.

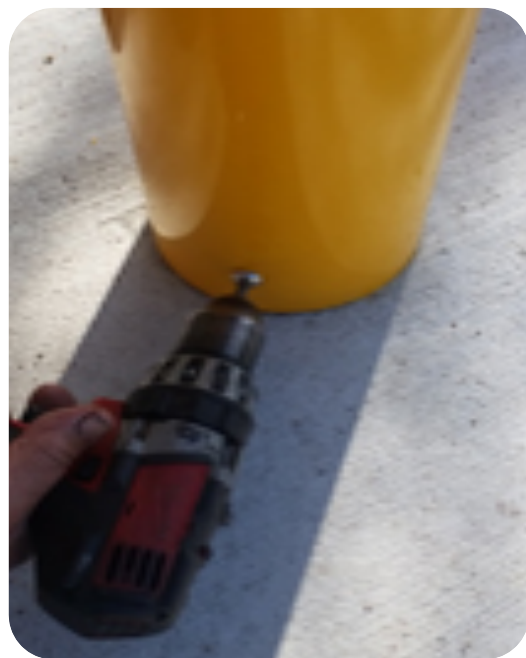

Resistance Core

Only replaceable component.

You should buy some of these for stock to ensure you can quickly replace damaged bollards. A standard Heavy Duty Galvanised Resistance Core is sufficient to prevent further forward movement of a passenger vehicle and reduce the risk of injury to drivers and vehicles. Suitable for all installations (Surface Mount/ 350 mm and 650 mm depth footings.)



S/MOUNT RESISTANCE CORE

Heavy Duty Galvanised Steel. 300 mm Length with securing stud to secure core to base

350 MM DEPTH RESISTANCE CORE

Heavy Duty Galvanised Steel. 350 mm Depth (650 mm Length) with self-locking Taper attached

650 MM DEPTH RESISTANCE CORE

Heavy or Extra Heavy Duty Galvanised Steel. 650 mm Depth (950 mm Length) with self-locking Taper attached

Extra Heavy Duty Resistance Core

If you find the resistance core is bending too frequently (often due to trucks of utility vehicles impacting them) you can increase the strength an Extra Heavy Duty Resistance Core. **This will increase the resistance by 150%** reducing the incidence of having to replace the inner core, but this strength internal resistance Core can only be used with 650 mm depth solid 30MPa concrete footings and will severely damage a passenger vehicle at high speed.

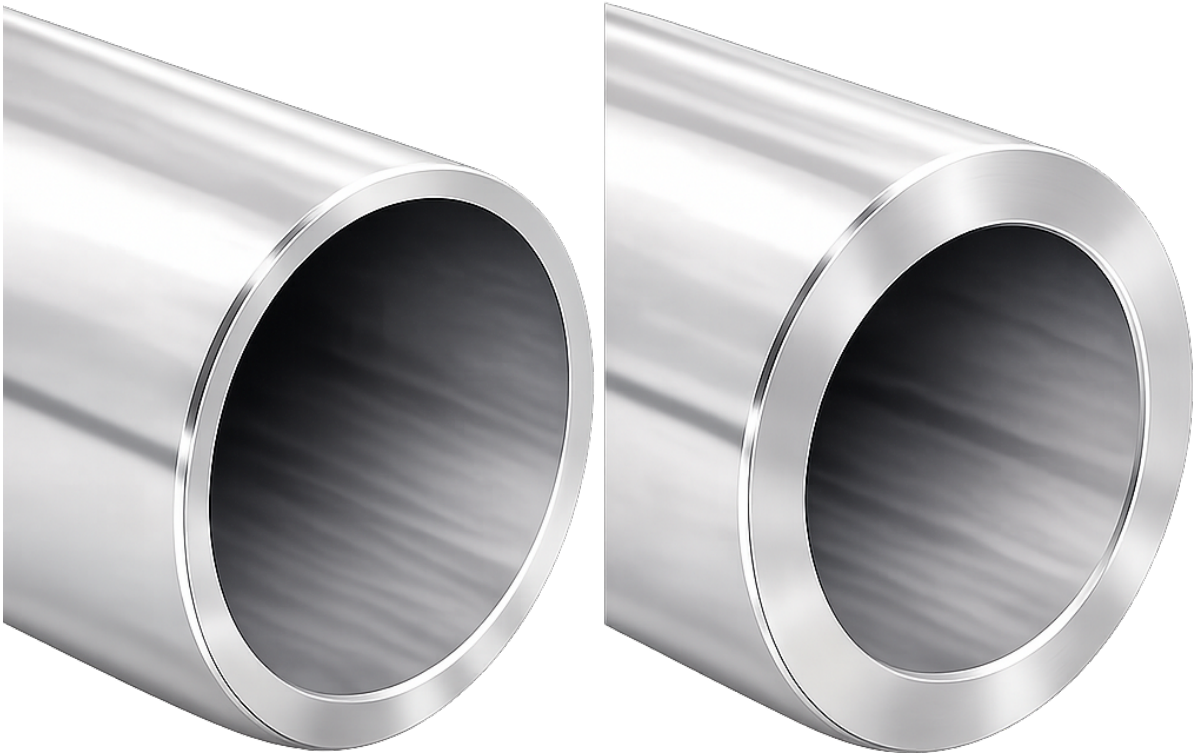

Heavy Duty Resistance Core

Extra Heavy-duty Resistance Core

When impacted

Bollards remain rigid and appear to be solid inground bollards (cannot be deflected by hand)

Upon Low Impact

When impacted by a vehicle they absorb the impact force deflecting a maximum of 20 degrees (when they are restricted any further deflection by the heavy duty Resistance Core) and self-recovering, with no diminished capacity following hundreds of impacts

Severe Impact

When severely impacted instead of the entire footing being dislodged, the inner resistance core bends allowing the bollard to fold but not be dislodged- preventing any further forward movement of the vehicle and enabling fast reinstatement



Removal/Replacement

Following severe impact, the bollard is removed the resistance core replaced and the bollard is reinstated in around five minutes.

The securing stud removed, the bollard slipped off the rings, and the resistance core removed using the ergonomic tool. The resistance core is replaced and the bollard and securing stud reinstated.

The foundations, Bollards and Impact Recovery Rings are all re-usable following multiple impacts.



TASK		HAZARDS		SAFE WORKING PROCEDURES
<p>Installing Sockets</p> 	<ul style="list-style-type: none"> - Bending of the back - Twisting of the back - Working in traffic 		<ul style="list-style-type: none"> • Dial before you dig • Install appropriate traffic management • Dig hole to insert ground socket • Insert installation tool inside ground socket • Lower install at on tool & socket into hole and fill with concrete. • Operate installation tool from standing position with straight back 	
<p>Installing Items</p> 	<ul style="list-style-type: none"> - Bending of the back - Twisting of the back - Working in traffic - Item not secure 		<ul style="list-style-type: none"> • Install appropriate traffic management/ cones • Attach Taper to item using self-drilling screws provided [This can be done just or to going, or able to reduce time on location] • For 2.8 - 5.5 mm wall thickness posts or large number of items, we suggest pre-drilling • Using two hands, drop item firmly into ground socket • Check item is sufficiently installed to protect from unauthorized removal 	
<p>Using Removal Tool</p> 	<ul style="list-style-type: none"> - Bending of the back - Twisting of the back - Working in traffic - Trapping of fingers 		<ul style="list-style-type: none"> • Position a minimum of two safety cones or safety barriers at extremity of working space • Face on-coming traffic when operating tool • Make sure the base of the tool is close as possible to the base of the item before applying jacking action • Apply downward quick jacking action to arm of tool • Lift item from ground socket using two arms (for items over 25 kg, 2 people must lift item from ground socket) • Bend knees to insert cap in ground socket • Carrying Tool: Hold upright stand and arm together in one hand to avoid trapping fingers 	

Resilient

bollards & road
infrastructure



Advanced engineering delivers superior projects and long term resilience,
building sustainable long term success



ZERO CIVIL
ZERO WASTE TECHNOLOGY

0414 628 511
hello@zerocivil.com
zerocivil.com

19 Gibberd Rd
Balcatta WA